

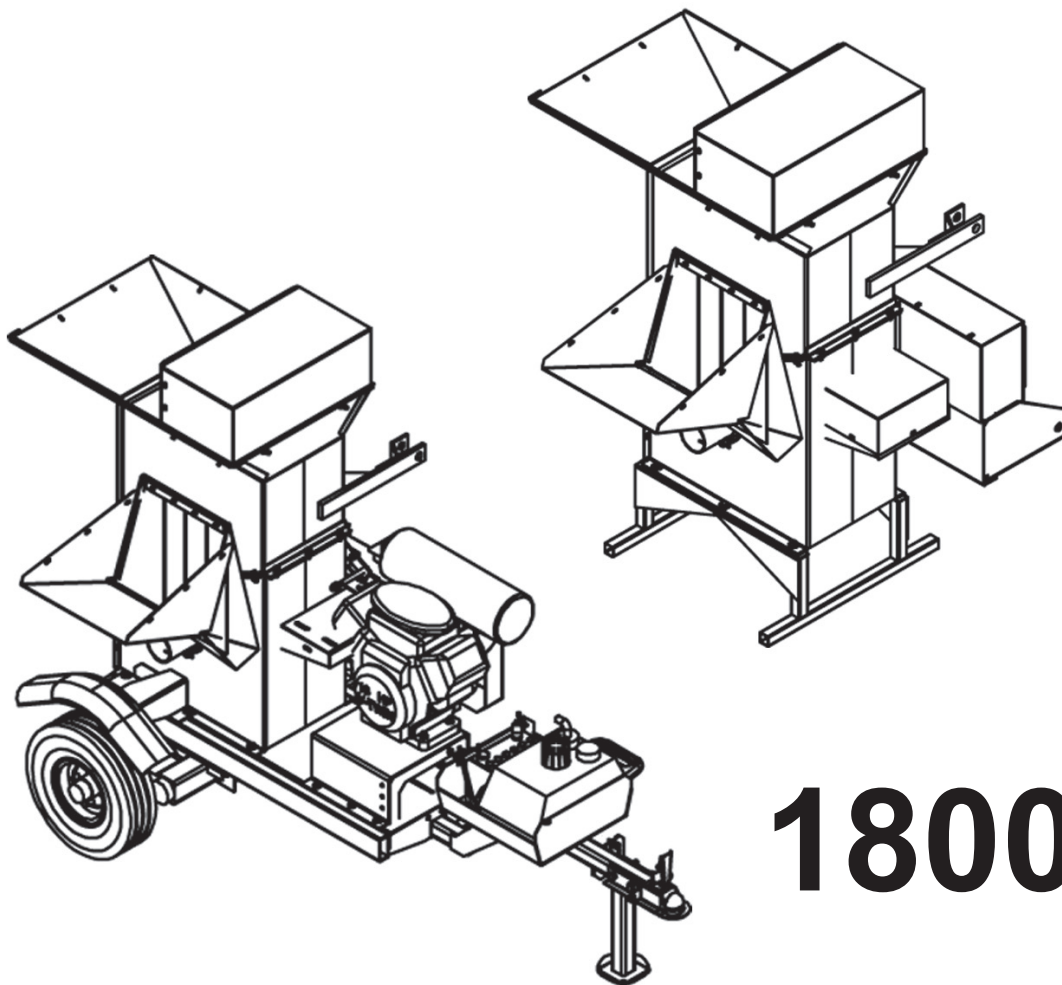

Chipper/Shredder

Operator's Manual



5400

1800

& Parts Manual

Thank you for purchasing a Harper Chipper/Shredder.

As with all Harper products, the Chipper/Shredder has been developed through tough design and testing procedures to produce a top quality machine. This manual gives assembly, operating, and service information for the model 1800 & 5400. Please read and understand all instructional material included with the Chipper/Shredder or its components before assembling and operating the equipment.

A Chipper/Shredder can present hazards to an operator who follows unsafe procedures in either the operation or maintenance of the unit. Therefore, **SAFETY WARNINGS** are presented at certain locations in the text.



THIS SYMBOL:

SAFETY WARNING!

MEANING: Failure to understand and obey this warning may result in injury to you or others. Whenever this symbol is used, please pay very close attention to the information presented, and make sure you fully understand. If you do not, contact your dealer or Harper Industries, Inc. for clarification.



SAFETY WARNING!

ALL SHIELDS AND GUARDS MUST BE IN PLACE FOR PROPER AND SAFE OPERATION OF THIS EQUIPMENT. WHERE THEY ARE SHOWN REMOVED IN THIS MANUAL, IT IS FOR PURPOSES OF ILLUSTRATION AND INSTRUCTION ONLY. DO NOT OPERATE THIS EQUIPMENT UNLESS ALL SHIELDS AND GUARDS ARE IN PLACE.

Harper Industries, Inc. is continually striving to improve the design and performance of its products. We reserve the right to make changes in specifications and design without thereby incurring any obligation relative to previously manufactured products.

© 2012 Harper Industries, Inc.

The Harper name is a registered trademark of Harper Industries, Inc. All other brand and product names are trademarks or registered trademarks of their respective companies.

LIMITED WARRANTY

The Harper 1800 & 5400 Chipper/Shedder is warranted against defects in workmanship and materials for a period of TWELVE MONTHS from the original date of retail purchase to the original purchaser.

Harper Industries will repair or replace, at our option, any part which our examination shows to be defective. Warranty is limited to parts, labor and ground freight delivery of replacement parts. The user will pay freight charges for parts submitted under this warranty.

No product or part may be returned for warranty consideration without prior approval from Harper Industries.

This warranty does not apply to parts subjected to misuse, abuse, alteration, improper or inadequate maintenance, or normal wear (including belts and broom).

Engines are not covered under this warranty. Refer to manufacturer's warranty for specific warranty information. Harper Industries, its agents or representatives, make or imply no other warranties.

RECORDS

Date of Purchase _____ / _____ / _____

Dealer's Name _____

Dealer's Phone _____

Serial Number Machine _____

Serial Number Engine _____

Table of Contents

OPERATOR SECTION

To the Owner or Operator.....	1
Warranty Statement.....	2
Table of Contents.....	3
Specifications.....	4
Torque Chart.....	4
General Safety Guidelines	
Before Operation.....	5
During Operation.....	5
During Service.....	5
Gasoline.....	6
Guards & Shields.....	6
Safety Decals.....	6
Specific Safety Guidelines	
CS-5400 PTO Powered Model.....	7
CS-1800 Gas Powered Model Engine.....	7
Towing.....	7
Control Identification	
CS-5400 PTO Powered Model	
PTO Shaft.....	8
3-Point Hitch Pins.....	8
Chipper Chute.....	8
Shredder Hopper.....	8
Jackshaft.....	8
Discharge.....	8
CS-1800 Gas Powered Model	
Engine Throttle Lever.....	8
Engine Choke Lever.....	8
Key Switch.....	8
Fuel Tank.....	8
Drive Sheaves, Belts, Bearings, & Shields.....	8
Trailer Hitch.....	8
Jack Stand.....	8
Chipper Chute.....	8
Shredder Hopper.....	8
Discharge.....	8
Assembly	
CS-5400 PTO Powered Model.....	9
CS-1800 Gas Powered Model Engine.....	9
Battery.....	9
Blower Attachment.....	10
Discharge Grates.....	11
Operation	
CS-5400 PTO Powered Model.....	12
CS-1800 Gas Powered Model Engine.....	12
Chipping.....	13
Shredding.....	13
Stopping Operation	
1800.....	13
5400.....	13
Adjustments	
Belt Tension.....	14
Belt Adjustment	
1800.....	14
5400.....	15

Service and Maintenance

Break-In Service.....	16
Lubrication.....	16
Chipper Knives.....	16
Shredder Knives.....	17

Troubleshooting	18
------------------------------	----

PARTS SECTION

CS-1800	
Chassis.....	22
Rotor Drive.....	23
Hitch.....	24
Hopper.....	25
CS-5400	
Assembly.....	26
Option - Blower Attachment.....	28
Rotor.....	31
1800 Decals.....	32
5400 Decals.....	33

Specifications

Hopper Size	34" x 21"
Chipper Plate	¾" thick machined and balanced steel plate
Chipper Knives	4 knives machined from tool steel
Chipper Chute	33"L x 13"W x 12"H
Chipper Capacity	5" maximum diameter material
Rotor	18" diameter with 36 free-swinging shredder knives
Shredder Capacity	1" to 1 ¼" maximum diameter material recommended
Grate	1 ½" grate is standard, ½" and ¾" are optional
Paint Finish	Durable polyester baked paint finish with epoxy primer <i>The paint finish is extremely strong, and resists chipping and cracking.</i>
Power	Gas Powered Model - 18 hp. Honda engine standard PTO Powered Model - 540 RPM from 18 to 30 HP tractor* * Warranty may be void if used on tractors over 30 HP.
Approximate Shipping Weight	Gas-800 lb. PTO-600 lb.

Torque Chart

Size	In. - Lb.	F-t. - Lb.	N - m
No. 10-24	25-35	5-7	2.8-4.0
1/4 in.	60-80	18-20	7-9
5/16 in.	120-140	28-30	14-16
3/8 in.	340-360	64-74	24-27
1/2 in.		126-150	90-100

NOTE: When tightening two or more screws on the same part, DO NOT tighten screws completely right away, or one at a time. To avoid distortion, first tighten all screws in sequence to one-third of torque value, then tighten to two-thirds of torque value, then tighten to full value.

General Safety Guidelines



SAFETY WARNING!

Failure to understand and obey these Safety Guidelines may result in injury to you or others.

Before Operation

- Check feed housings for children, pets and foreign objects before operating.
- Check to ensure that all belt guides are in place to prevent belts from slipping off the pulleys and systems from being accidentally engaged.

During Operation

- Wear approved eye and ear protection while operating the Chipper/Shredder.
- Keep all guards in place during operation.
- Never operate the Chipper/Shredder with safety shields removed.
- Never allow hands, clothing or any part of the body to enter the discharge chute, feed chamber or near any moving parts.
- When placing material into the machine, make certain there are no foreign objects such as rocks, cans, bottles or other hard materials included.
- Keep processed material from building up in the discharge area, as this may prohibit proper discharge and cause a back-feed of material through the feed opening.
- Keep the engine area clean from debris and other accumulations.
- Keep all safety shields and guards in place and in good working condition.
- Keep your face and all body parts away from feed openings.
- Stay away from the discharge area when machine is in operation.
- Always keep proper balance and footing, never overreach.

- If a foreign object should strike the cutting mechanism of the machine and cause an unusual noise or vibration, shut the PTO engine off immediately and allow it to come to a complete stop. Disconnect the spark plug wire from the spark plug, or PTO from the power unit, and then do the following:

1. Inspect for damage.
2. Repair or replace any damaged parts.
3. Check for and tighten any loose bolts, nuts, fasteners or parts.

- Never attempt to move or transport Chipper/Shredder while engine or rotor is still operating.
- If the Chipper/Shredder should be come clogged, shut off the engine or PTO and allow it to come to a complete stop. Disconnect the spark plug wire or PTO shaft before clearing debris.

During Service

- Replace locknuts and locking screws if they can be tightened without feeling resistance for several turns before they are completely tight. Replace them with factory-authorized parts or their equivalent.
- If hardware is not secure, or if some of the hardware is over-tightened, equipment failure may result, posing possible safety hazards.
- Use genuine factory parts or parts with equivalent characteristics, including type, strength and material. Failure to do so may result in product malfunction and possible injury to the operator or others.
- To prevent possible eye injury, always wear SAFETY GLASSES while servicing the equipment

Gasoline



Gasoline is extremely flammable and can be highly explosive.

Always keep a fire extinguisher near the Chipper/Shredder during operation.

- Always use an approved container for gasoline.
- Avoid open flames or sparks while doing maintenance or refueling.
- Never remove the fuel tank cap or add gasoline when the engine is running or while it is hot.
- Never fill the fuel tank indoors (fumes can collect).
- Wipe up spilled gasoline immediately.
- Do not store gasoline in a room with an appliance that has a pilot light, or where electrical appliances with automatic switches could cause sparks.
- Always store gasoline outside in a safety can (a can which has a flame arrestor and pressure relief valve in pour spout).
- Gasoline fumes are heavy and will sink to the lowest point, collecting and becoming more and more hazardous. 1 part gasoline in 20 parts air will explode easily and violently.
- Never store the equipment with gasoline in the tank inside a building where fumes may reach an open flame or spark. Allow the engine to cool before storing in any enclosure.

Guards & Shields

- Keep the equipment and attachments in good operating condition.
- Keep all safety devices in place.
- Replace all worn, damaged, unusable, missing or lost safety shields and guards before operating the equipment.

Safety Decals

- If safety related or instructional decals become illegible or are removed, replace them immediately.
- If you replace parts that have decals attached to them, make sure the decals are replaced with current versions, and that decals are on the replacement parts before the machine is operated again.
- New decals may be obtained from your local Harper Dealer.

Specific Safety Guidelines

CS-5400 PTO Powered Model

- Never operate the PTO unit when tractor is moving. Machine should only be operating when setting level on ground surface.
- To move the unit, shut the PTO off. Lift the 3-point hitch, and then move to the desired location.
- Keep hands, feet and clothing away from PTO driven parts.
- Keep all guards and shields in place during operation. Disengage PTO and shut off the engine before removing guards or shields.
- Never attempt to adjust, clean or lubricate the machine while it is in operation.
- Operator should never wear loose clothing when working around PTO.
- Before starting tractor, make sure that the transmission and PTO are disengaged.
- A belt between the PTO shaft and the rotor shaft drives the cutting blades whenever the PTO shaft is turning.



SAFETY WARNING!

Recommended tractor PTO horsepower is 18 to 30 HP. Use of tractors above 30 HP may cause belt damage and will void warranty.



SAFETY WARNING!

Cutting blade rotation cannot be controlled from the Chipper/Shredder.

CS-1800 Gas Powered Model Engine

- Be certain to provide adequate ventilation if an engine must be run indoors - exhaust fumes are dangerous.
- Periodically clean chopped material away from engine to lessen the possibility of fire.

- Always keep a fire extinguisher near the Chipper/ Shredder during operation.
- Engine governor settings are pre-set and should not be changed; any change can damage moving parts and void the warranty.
- Keep clothing and all body parts away from rotating parts.

Towing

- A 2" ball is required to tow this unit. Make sure bolts holding tongue are secure and always use a safety chain.
- When towing, travel at speed safe for conditions. Do not exceed 30 mph. Always have jack in transport position.
- Tire pressure should be 60 psi. Make sure all wheel lug nuts are tight.



SAFETY WARNING!

Gasoline is extremely flammable and can be highly explosive. To minimize the danger:

- Always use an approved container for gasoline.
- Do not allow open flames or sparks while performing maintenance or refueling.
- Never remove the fuel tank cap or add gasoline when the engine is running or hot.
- Refer to Engine manual for additional information on gasoline.

Control Identification

CS-5400 PTO Powered Model

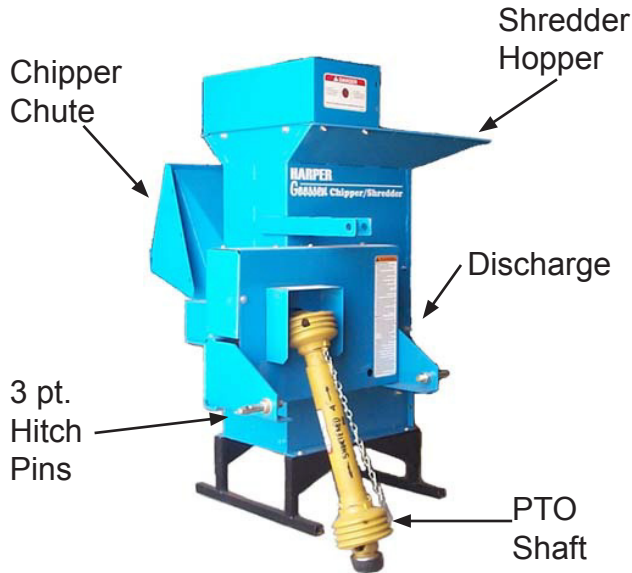

PTO Shaft - Transfers power from the tractor to the Chipper/Shredder. Due to variations in tractor styles, the operator is responsible for ensuring that the PTO shaft is the correct length for a given tractor. (See the Assembly instructions.)

3-Point Hitch Pins - Mounts the Chipper/Shredder to the 3-Point Hitch of the tractor.

Chipper Chute - Materials to be chipped are fed into the chipper chute.

Shredder Hopper - Materials to be shredded are fed into the shredder hopper.

Jackshaft - The jackshaft is connected to the PTO shaft and used to adjust tension for drive belts.

Discharge - The area where chipped and shredded materials are discharged.



SAFETY WARNING!

Make sure that angle of PTO shaft does not exceed 15 degrees.

CS-1800 18 HP Gas Powered Model

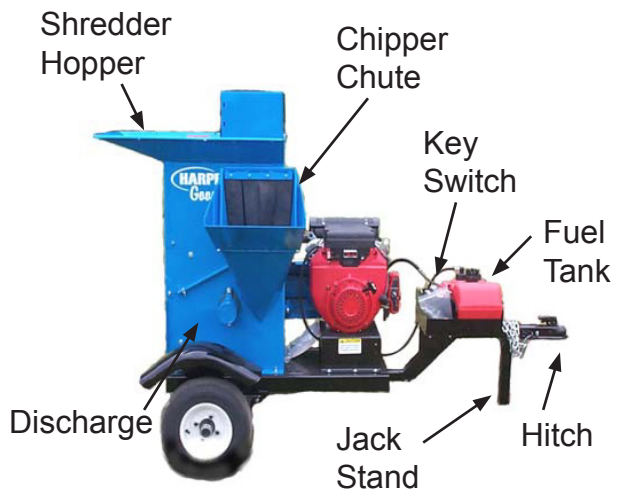

Engine Throttle Lever - The throttle lever controls engine speed and ranges from full throttle operation to low idle for warm up.

Engine Choke Lever - The choke lever is used in cold starting situations. Refer to engine manual for starting instructions.

Key Switch - The key switch is used for starting the engine.

Fuel Tank - The fuel tank is located on the hitch and has a 3-gal. capacity. Refer to engine manual for fuel recommendations.

Make sure vent is open before operation.

Drive Sheaves, Belts, Bearings and Shields - All are driven from the engine. (Not shown in photo.)

Trailer Hitch - Tow unit with a 2" ball only. Always use a safety chain. This unit is not designed for highway use - 30 MPH max.

Jack Stand - The jack stand should always be in the up position when transporting. When operating Chipper/Shredder it should be down and locked.

Chipper Chute - Materials to be chipped are fed into the chipper chute.

Shredder Hopper - Materials to be shredded are fed into the shredder hopper.

Discharge - The area where chipped and shredded materials are discharged.

Assembly

CS-5400 PTO Powered Model

1. Mount feet onto machine base.
2. Connect PTO shaft to input shaft of machine, tighten set screws on shaft.
3. Mount 3-point hitch pins onto Chipper/Shredder.
4. Mount Chipper/Shredder to 3-point hitch of tractor and secure with lynch pins.
IMPORTANT: Do not connect the PTO shaft at this time.
5. Raise the unit to the height where the PTO shaft would be level if installed (PTO shaft should be at shortest length).
6. Hold the PTO shaft alongside the 540 yoke on the tractor and allow for $\frac{3}{4}$ " clearance between the outer shield and the bell housing at the Chipper/Shredder end of the PTO shaft.
7. If the PTO shaft is too long, separate the halves and cut the full amount of excess length from both the male and female half.

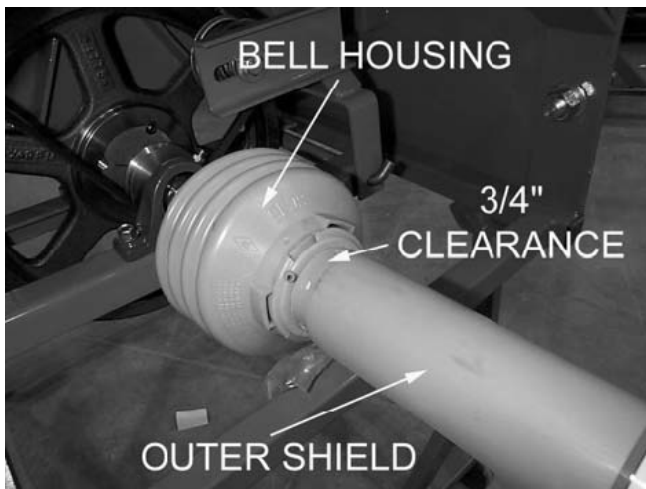

Note: If only one end is cut from the PTO shaft, the other end will bottom out during operation. Cut the inner and outer shields to compensate for the length adjustment.

8. Connect the PTO shaft to the 540 yoke on the tractor to begin operation.

! SAFETY WARNING! !

- Keep pants and loose clothing away from PTO shaft and all other shafts, pulleys and belts.
- Never operate the Chipper/Shredder beyond the suggested 540 PTO speed.
- Do not attempt to service machine while it is in operation.

CS-1800 18 hp. Gas Powered Model

1. Mount tires and rims onto spindles.
2. Install trailer tongue to trailer using hardware provided.
3. Mount 12-volt battery onto box on trailer tongue and connect cables.

Battery

! SAFETY WARNING! !

The battery is shipped without electrolyte. Therefore, the battery must be filled with sulfuric acid electrolyte before the Chipper/Shredder can be operated.

Electrolyte:

1. Place the battery on a level surface and remove the vent caps. If the battery has thin plastic shields in the cell openings, remove and discard them.
2. Fill the battery with battery grade sulfuric acid to just above the separators.

DO NOT OVERFILL

3. Reinstall the vent caps, then charge the battery as instructed below. AFTER charging, check the acid level, and fill to the bottom of the vent well openings.

DO NOT OVERFILL

Charging:

1. Make sure the vent caps included with the battery are installed.

2. Connect the battery to a charger according to the manufacturer's instructions and charge at 10 amperes for 50 minutes, or 2-9 amperes for 2 hours (depending on capability of the charger).

Installation:

1. Make sure the cable terminals and any hold-down parts are clean. If the battery is a replacement and the connectors and hold-down parts have been used before; clean them with a wire brush.
2. Place the battery in the box with the terminals on the side nearest the tongue, and secure the battery in position with hold-down parts provided.
3. Connect the cables to the proper terminals, connecting the **UNGROUND**ED cable first. Do not over-tighten. Apply a commercial battery anti-corrosion material or petroleum jelly to the terminals to minimize corrosion.

! SAFETY WARNING! !

- **Battery electrolyte can cause severe burns if handled improperly. Observe all poison/danger warnings on electrolyte cartons and on the battery.**
- **Wear splash-proof goggles and protective clothing when adding electrolyte to batteries.**
- **Avoid contact of electrolyte with skin, eyes, or clothing.**
- **Keep batteries and electrolyte OUT OF REACH OF CHILDREN.**
- **If electrolyte is spilled or splashed on the body, IMMEDIATELY FLUSH WITH WATER.**
- **If electrolyte comes into contact with the eyes, FLUSH WITH WATER FOR 15 MINUTES AND GET PROMPT MEDICAL ATTENTION.**

- **If electrolyte is taken internally, DRINK LARGE QUANTITIES OF WATER OR MILK, FOLLOWED WITH MILK OF MAGNESIA, BEATEN EGGS, OR VEGETABLE OIL.**

! SAFETY WARNING! !

- **The battery can produce explosive gases. Ventilate when charging or using in an enclosed space.**
- **DO NOT produce sparks from cable clamps, tools or other sources.**
- **DO NOT allow flames or smoking in the vicinity of the battery.**
- **Shield eyes when working near the battery.**
- **Keep the vent caps tight and level.**

Blower Attachment

1. Remove blower and directional spout from boxes.
2. Remove rear shaft guard and safety door from Chipper/Shredder.
3. Mount blower attachment to Chipper/Shredder using safety door hinge pin, secure blower to unit using 4 - 5/16" x 3/4" bolts and 5/16" nylock nuts.
4. Install belt shield mount tab on top bolt of bearing using 1/2" lock nut.



5. Mount drive pulley on drum shaft. Align pulleys and tighten to 17 ft-lb. Mount belt on unit routing idler in center of belt. Install belt shield using 5/16" bolts and flat washers.
6. Mount lower directional spout to blower using 5/16" bolts and flat washers.
7. Mount upper directional spout to lower using 5/16" x 3/4" bolts, 5/16" lock nuts and bearings. Make sure that 1/4" washer is placed between bearing and mount tab.
8. Mount crank assembly to mount tab using 2 3/8" x 1" carriage bolts and 3/8" nylock nuts. Place 2 3/8" flat washers under each bolt location to shim up crank assy.
NOTE: This may vary due to required clearance for crank.
9. Mount deflector spout to upper spout using 2 5/16" x 3/4" truss head bolts. A 5/16" washer is used for a spacer between deflector and spout.

Discharge Grates

- The factory-installed standard discharge grate has 1 1/2" diameter holes.



- Installing a discharge grate with smaller diameter holes can increase fineness of the shredded material.
- Discharge grates with 1/2" and 3/4" diameter holes are available for the Chipper/Shredder.

- A discharge grate with parallel bars is available for shredding leaves or green material.

To change discharge grates:

1. Remove the rear door hinge pin and remove the rear safety door.
2. Remove the 6- 3/8" x 1" bolts holding the grate in place. Remove the grate.

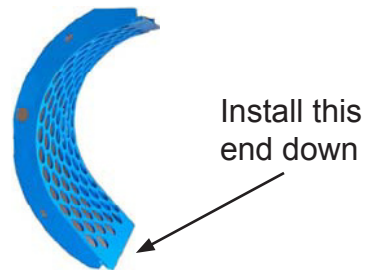

3. Install new grate. Make sure to install the rounded edge of the grate to the bottom.
4. Reinstall bolts and rear safety door.

! SAFETY WARNING! !

- The cutting rotor is heavy and will continue to turn even though the operator has shut off the power source. Do not attempt to service or inspect the machine until you see that the shafts have stopped turning and that there is no noise coming from the machine.
- Never operate Chipper/Shredder without ALL GUARDS in place.

Operation

SAFETY WARNING!

- Obtain and wear safety glasses when operating this machine. Do not wear loose fitting clothing. Operator should always wear heavy-duty gloves, boots, and other articles of clothing.
- A safe operator is one who practices safety and uses good common sense to protect him or herself from sharp objects and branches.
- Move the Chipper/Shredder to a clear level area outdoors before operating. Do not operate on uneven, paved or other hard surfaced areas. Do not operate in the vicinity of bystanders.
- To avoid personal injury, always keep face and body parts away from feed openings. Never over-reach and keep proper footing and balance.

CS-5400 PTO Powered Model

1. Obtain and wear safety goggles before operating the Chipper/Shredder.
2. Check feed housings for children, pets and foreign objects before operating.
3. Mount PTO Chipper/Shredder to 3-point of tractor and connect PTO shaft to tractor output shaft.
4. Adjust center link on tractor so that the Chipper/Shredder is setting level at the ground surface.
5. Move the Chipper/Shredder to a clear level area outdoors before operating. Do not operate on uneven, paved or other hard surfaced areas. Do not operate in the vicinity of bystanders.
6. Engage tractor PTO to begin operation.

CS-1800 18 HP Gas Powered Model

1. Obtain and wear safety goggles before operating the Chipper/Shredder.
2. Check feed housings for children, pets and foreign objects before operating.
3. Before operating, fill the tank with gasoline. (Refer to engine manual for further information.)
4. Make sure the vent cap on the fuel tank is open at least a quarter of a turn. (If the vent is completely closed the engine will vapor lock and not run.)
5. Move the Chipper/Shredder to a clear level area outdoors before operating. Do not operate on uneven, paved or other hard surfaced areas. Do not operate in the vicinity of bystanders.
6. Open throttle to half way and place the choke lever to the full open position.
7. Turn the key switch to the start position and release as soon as the engine starts. **DO NOT TURN THE STARTER OVER FOR MORE THAN 10 SECONDS.**
8. Once the engine is running, gradually move the choke lever to the off position, and allow the engine to warm up before opening the throttle to full speed.
9. When restarting a warm engine, it should not be necessary to use the choke lever. If choking is necessary, open the lever only halfway. (Refer to engine manual for more information.)
10. Move engagement handle on machine to begin operation.

SAFETY WARNING!

Do not exceed 30 MPH when towing the unit. Travel at speeds that are appropriate for conditions and always use safety chains.

SAFETY WARNING!

Gasoline is highly flammable and can be highly explosive. See Safety Guidelines section for more information.

Chipping

- Select limbs that are up to 5 inches in diameter; trim branches that will not fit into the chipper chute. Smaller branches can be bunched and ran through together.
- Place limb, butt end first, into the chipper chute until it touches the chipper knives.
The feed rate of the limb into the chipper depends on the material and sharpness of the chipper knives. The operator can feed the limb by alternately inserting and retracting the limb or continuously feeding it, so long as it doesn't kill the engine or the tractor. By rotating the limb you can improve the cutting action of the chipper.
- The chipping knives will become dull at varying times depending on the wood material used. Periodic sharpening of knives will be required. Refer to the Service & Maintenance section for sharpening instructions.

Shredding

- Feed material such as grass, leaves, garden refuse, and branches up to 1" in diameter and 36" long into the shredder hopper.
- Use a leaf tamper, branch or similar object to push light material into shredding chamber.
- Feed material at an even pace to avoid plugging or lugging of the Chipper/Shredder. If the shredder should become plugged, refer to the service section of the manual before clearing plugged material. Branches or material that cause plugging or slow operation should be fed at a slower pace to avoid plugging.

SAFETY WARNING!

- **Never leave the machine unattended, or attempt service or inspection unless the machine has come to a complete stop, the engine has been shut off, and the spark plug has been disconnected.**
- **On PTO units, make sure the PTO and the tractor engine has been shut off and the machine has come to a complete stop.**

NOTE: To avoid entanglement with material going into the shredder hopper it is suggested to use a throwing motion when feeding material.

Stopping Operation

CS-1800 18 HP Gas Powered Model

1. Move the throttle lever to the slow position and disengage manual engage lever.
2. Shut off the engine and allow the machine to come to a complete stop.
3. If it is necessary to inspect or work on the Chipper/Shredder, remove the spark plug wire from the spark plug.

CS-5400 PTO Powered Model

1. Move throttle on tractor to the slow position and disengage the PTO lever on the tractor.
2. Shut off the tractor engine and allow the machine to come to a complete stop.
3. If it is necessary to inspect or work on the Chipper/Shredder, always disengage the PTO and shut off the tractor engine before doing so.

Adjustments

! SAFETY WARNING! !

- The cutting rotor is heavy and will continue to turn even though the operator has shut off the power source. Do not attempt to service or inspect the machine until you see that the shafts have stopped turning and that there is no noise coming from the machine.
- If the operator wants to slow the machine faster, he can do so by inserting a limb into the chipper chute so that it contacts the knives and slows the machine down.
- Never operate Chipper/Shredder without ALL GUARDS in place.

Belt Tension

- On initial operation of the Chipper/Shredder, the belts may shrink and need readjustment after the first hour of use.
- Check the condition of drive belts before each use or after every 25 hours of operation.
- Use only industrial V-belts. Do not use automotive belts.
- Do not over tighten belts. Excessive tension can cause premature bearing and belt failure.
- Use a straightedge to check alignment across the faces of pulleys after adjusting belt tension to ensure that the belts will run true.

Belt Adjustment

CS-5400 PTO Powered Model

1. Make certain that PTO shaft is removed from power source and un-mounted from 3-point hitch of tractor.

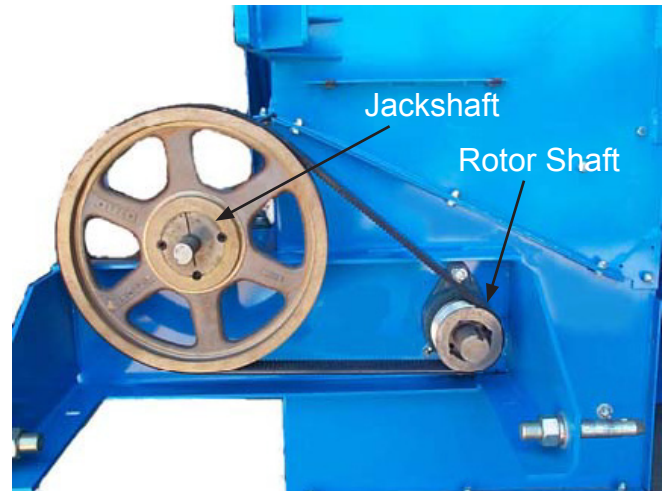

2. Disconnect PTO shaft from Chipper/Shredder and remove belt guards.

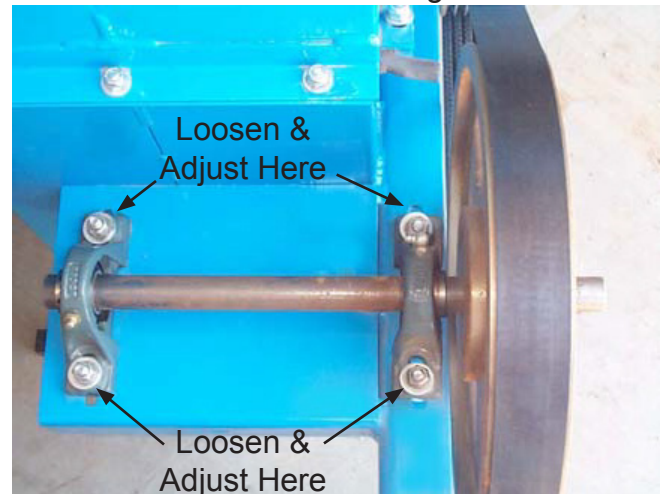

3. Loosen bolts that mount the jackshaft pillow block bearings and move the shaft towards the frame.
4. Remove the belt. Inspect or replace with a new belt.
5. Move shaft away from frame to tighten belt and check to see that there is no more than 1/4" up and down play in the belt.
6. Snug two bolts and check pulley alignment with a straightedge. If not aligned, loosen one bolt and adjust. Tighten all bolts on bearings when alignment is achieved.

CS-1800 18 HP Gas Powered Model

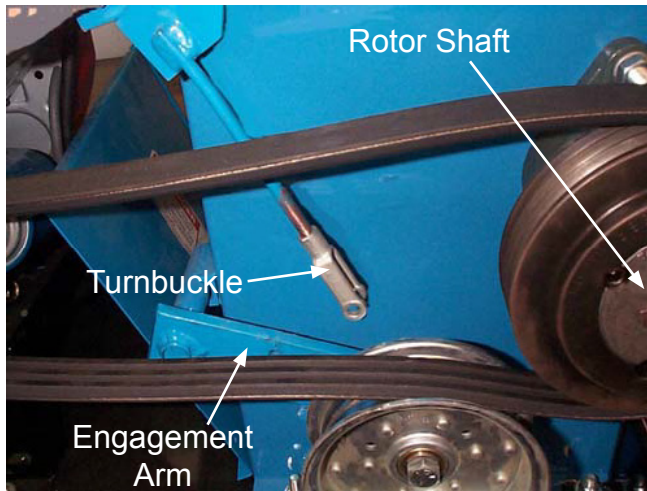

1. Remove belt shield.
2. Located below the manual engage lever is a turnbuckle. Remove the cotter pin and turnbuckle pin.
3. Turn the turnbuckle in whichever direction is needed to acquire proper belt tension. There should be no more than ¼" up and down play in the belt.
4. Replace turnbuckle pin and cotter pin and recheck adjustment. If necessary, readjust.
5. Replace belt shield.

If adjustment requires more than what is available at the turnbuckle, then do the following:

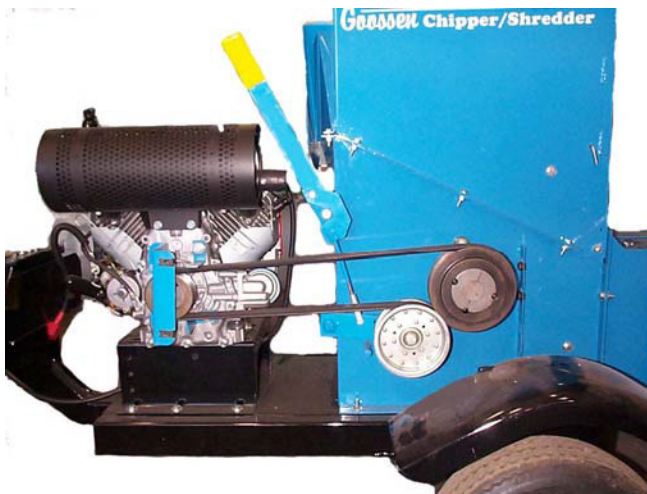

1. Loosen the four 3/8" x 1 1/2" bolts holding the engine.
2. Remove the belt and inspect or replace it.
3. Reinstall belt and draw engine back until there is ¼" up and down play in the belt. Use a straightedge and check for proper alignment.
4. Tighten four engine bolts and replace safety shield.

! SAFETY WARNING! !

Before working on this machine, disconnect spark plug wire from the spark plug and remove the positive wire from the battery.

Belt Guide Adjustment

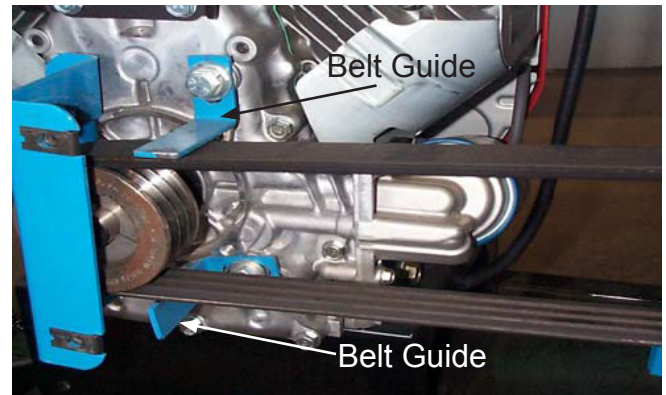

For proper belt operation, adjustment of the belt guides located on the engine is necessary.

1. Turn engine off, remove wire from spark plug and remove belt shield.
2. Check clearance between belt guide and belt with drive sheave engaged. Clearance should be 1/8".
3. If adjustment is needed, loosen the 7/16" x 1 ¼" bolts.
4. Adjust guide until 1/8" clearance is reached.
5. Retighten the bolts to the specified torque ratings.
6. Replace belt shield.

Service & Maintenance

SAFETY WARNING!

- Before servicing or inspecting the Chipper/Shredder, make sure the power source is shut off and all moving parts have stopped.
- Disconnect the spark plug wire from the spark plug on Gas Powered units.
On PTO Powered units, disconnect the PTO shaft from the tractor.
- Always wear safety glasses and protective gloves when servicing the Chipper/Shredder.

Break-In Service

- After the first hour of use:
- Check belts. Re-tension if needed.
- Tighten set screws on bearings.
- Check nuts, bolts and fasteners to see that they are secure.

Lubrication

- Lubricate grease fittings after every 50 hours of use.
- There are 2 fittings on the rotor shaft of both the Gas and PTO Powered models.
- The PTO Powered model also has 2 fittings on the jackshaft and 2 fittings on the PTO shaft.

SAFETY WARNING!

- Wear protective gloves whenever handling or working near knives.
- Knives and their retaining hardware rotate at high speed. It is essential that they be mounted as described in the instructions to prevent accidents from flying metal.

Chipper Knives

Depending on the type of wood being fed into the chipper, the knives eventually become dulled, slowing chipping time and making it harder to produce chips. It is recommended that chipper knives be sharpened every 5 to 10 hours of use.

Removal:

1. Remove the nine 5/16" bolts that fasten the top and bottom housings together.
2. Remove the bolts that fasten the top of the grate and open hinged housing to access drum housing.
3. Rotate drum so that knife is most accessible through chipper chute.
Remove the two 5/16" bolts and the chipper knife. Repeat this step for the remaining knives.

Sharpening:

- The chipper blades can be sharpened with a bench grinder or done by a Harper dealership.
- Avoid getting blade surface too hot to where it changes color. This will remove the heat-treatment and may attribute to premature failure. When grinding, use short grinding intervals and cool in between with water.
- Remove equal amounts to keep knives balanced. Re grind knife-edge to 35 degrees of angle. Failure to do so may affect chipping performance.

Mounting:

1. Mount chipper knives to rotor plate with sharpened edge facing chipper chute. Use Grade 5 5/16" x 1" bolts that have been treated with Loctite® or equivalent.
2. After knives are mounted, tighten bolts to specified torque using the Standard Torque Chart.
3. Re-assemble housing.

Setting Clearance:

1. Remove safety shields covering the drive pulley on the rotor shaft front.
2. Remove safety cover on rotor shaft rear side.
3. Loosen screws on the rotor shaft pulley.
4. Loosen set screws on front and rear rotor bearing lock collars.
5. Using a hammer and punch, tap the lock collars opposite the direction of normal rotation and remove.
6. Tap the end of the rotor shaft until the necessary 1/16 to 1/8 clearance between the knife and chipping block is obtained.
7. After clearance is set, replace lock collars onto eccentric hub on bearings.
8. Rotate the lock collars in the direction of the shaft rotation and set them with a hammer and punch.
9. Using a straight edge, align rotor pulley with the drive pulley and tighten to 17 FT LBS. Set bushing with a punch and re-torque.
10. Inspect and make sure all parts are aligned and tight.
11. Close top half of drum housing, install bolts and tighten. Replace grate pin in top of grate assembly.
12. Make certain all bolts and fasteners are tight and secure before replacing shields and guards.

Shredder Knives

NOTE: The serrated shredder knives can be rotated four times and re-sharpened.

Removal:

1. Remove the nine 5/16" bolts that fasten the top and bottom housings together.
2. Remove the pin that fastens the top of the grate and open hinged housing to access drum housing.
3. Remove the #10-24 bolt and nut from the knife shaft. Work with one shaft at a time only; this will eliminate any confusion as to proper spacing and alignment.

4. Remove the knife shaft, knives and spacers, and reverse or replace desired shredder knives.

Reversing or Replacing:

NOTE: Replace knives and spacers in the same manner they are removed. (See Fig. 1) This will eliminate improper balance and misalignment of knives, which may cause damage to the machine and void warranty.

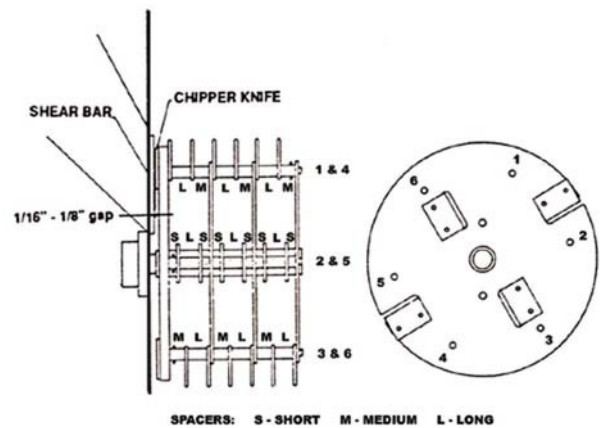

Fig. 1

1. Replace #10-24 bolt and nut through end spacer and torque to the specified torque value in the Standard Torque Chart.
2. Service all remaining knife shafts in this manner.
3. Inspect and make sure all parts are aligned and tight.
4. Close top half of rotor housing, install bolts and tighten. Replace grate pin in top of grate assembly.
5. Make certain that all bolts and fasteners are tight and secure before operating.

NOTE: If unit is equipped with a Blower Attachment, you will need to remove the Blower before reversing or replacing the shredder knives.

Troubleshooting

Engine

Problem	What to Check
Engine will not start.	<ul style="list-style-type: none"> • Improper control settings. • Engine may be low on fuel. • Engine may be low on oil. (The Honda Engine is equipped with "Oil-Alert" automatic shut-off) • Battery charge may be too low. • Possible internal problems. • Fuel tank vent may be closed.
Problem	What to Check
Engine shuts off during operation.	<ul style="list-style-type: none"> • Engine may be low on fuel. • Engine may be low on oil. (The Honda Engine is equipped with "Oil-Alert" automatic shut-off) • Air breather may be clogged.

Belts

Problem	What to Check
Belts Slip	<ul style="list-style-type: none"> • Tension adjustment. • Load may be excessive. • Knives may be too dull. • Foreign material may be lodged in the chipper or shredder housing. • Bearings may have seized.
Problem	What to Check
Belts wear rapidly, jump, catch, or twist.	<ul style="list-style-type: none"> • Pulleys may not be properly aligned. • Check with straightedge across faces of pulleys.

Cutting and Discharge

Problem	What to Check
Chipper is hard to feed.	<ul style="list-style-type: none"> • Discharge plugged. • Dull chipper knives. • Improper knife clearance.

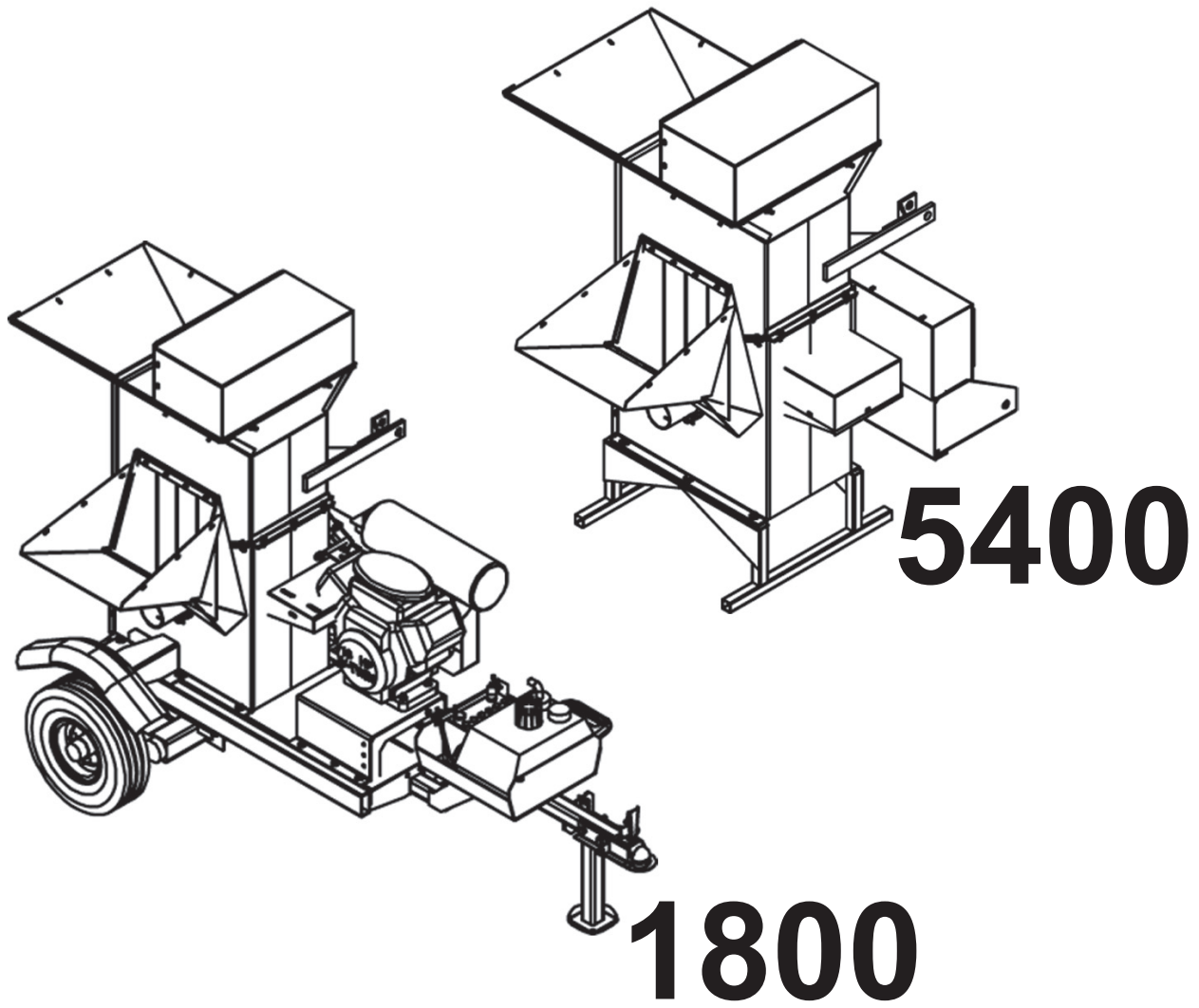

Parts Section

Table of Contents

PARTS SECTION

CS-1800	
Chassis.....	22
Rotor Drive.....	23
Hitch.....	24
Hopper.....	25
CS-5400	
Assembly.....	26
Option - Blower Attachment.....	28
Rotor.....	31
1800 Decals.....	32
5400 Decals.....	33

CS1800 CHASSIS

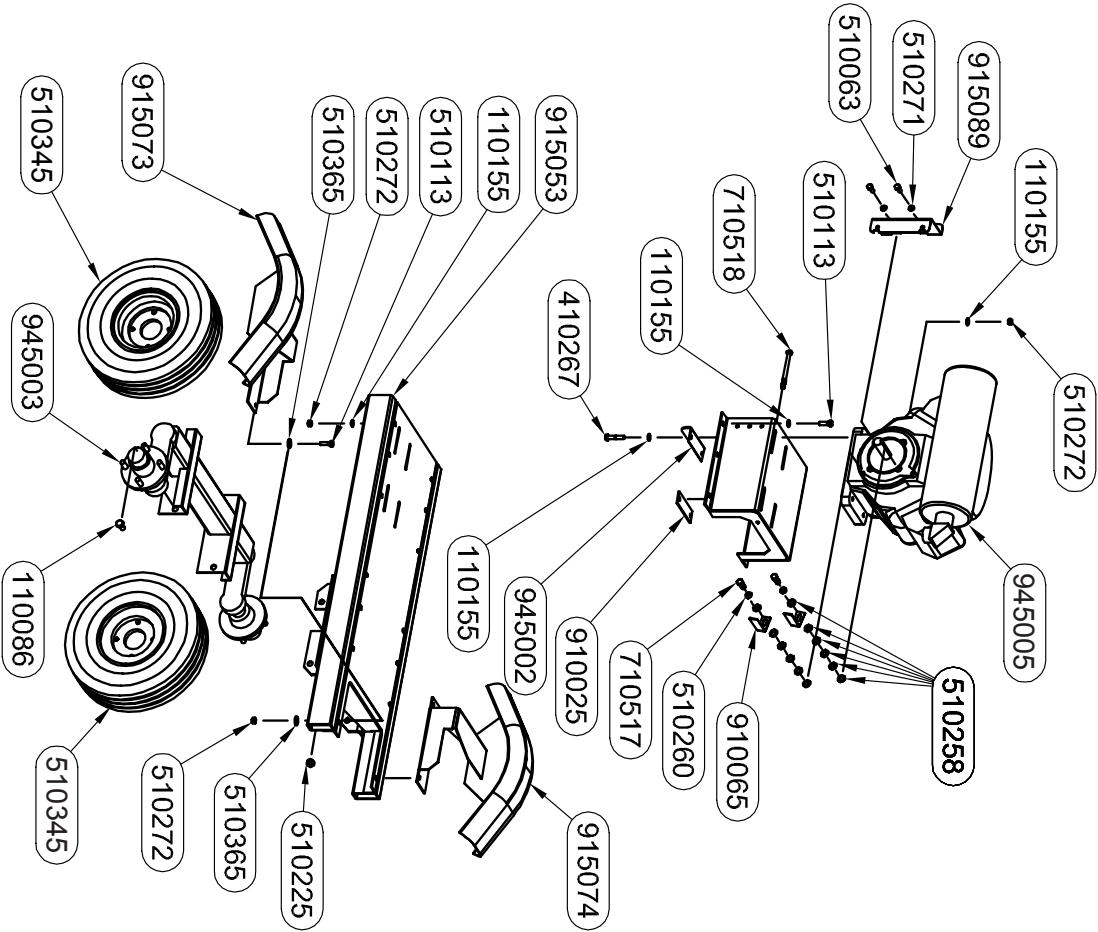

PART #	QTY	NAME
915074	1	RIGHT FENDER
915073	1	LEFT FENDER
915069	1	MOTOR MOUNT
910025	1	MOTOR MOUNT PLATE
945002	1	MOTOR TENSIONER
945005	1	MUFFLER KIT 18HP HONDA
915089	1	BELT GUILD
910065	2	GUIDE, LOWER DRIVE BELT
510345	2	TIRE AND WHEEL
915053	1	TRAILER
945003	1	TORSION AXLE
510113	12	BOLT, 3/8-16 X 1.25
110155	4	WASHER, 3/8 FLAT, "SAE"
510272	2	NUT, 3/8-16
710518	1	BOLT, 3/8-16 X 4.5
410267	4	BOLT, 3/8-16 X 2
110086	4	BOLT, 1/2-13 X 1
510225	9	NUT, 1/2-13
510365	12	WASHER, FLAT .375 STANDARD
510063	6	BOLT, 3/8-16 X 1
510271	2	WASHER, 3/8 LOCK
710517	2	BOLT, 7/16-14 X 1.25
510258	12	WASHER, 7/16 FLAT
510260	2	WASHER, 7/16 LOCK

CS1800 ROTOR DRIVE

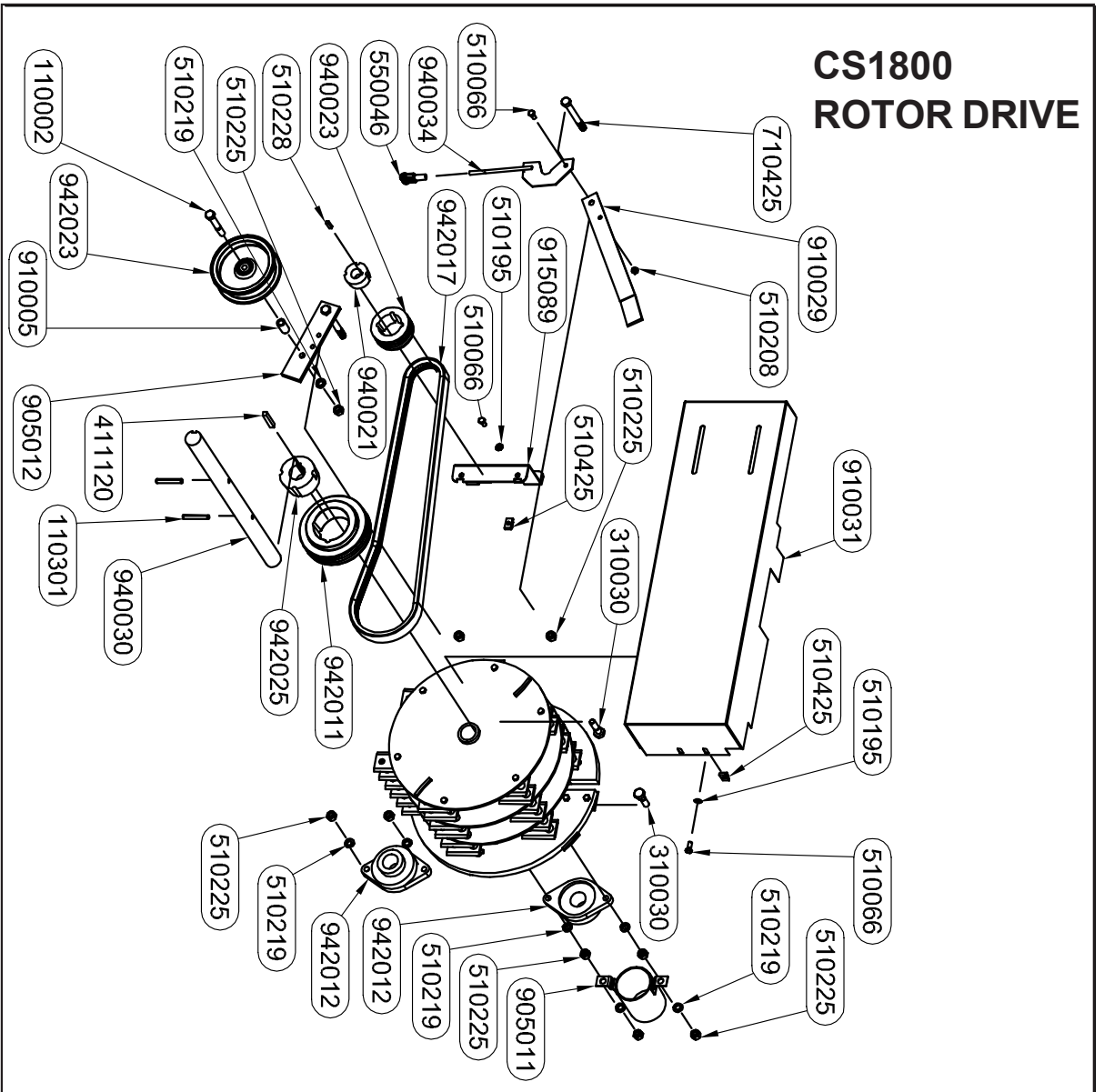

PART #	QTY	NAME
940030	1	ROTOR SHAFT
910005	1	IDLER PULLEY SPACER
942017	1	DRIVE BELT
550046	1	CLEVIS YOKE
942023	1	IDLER PULLEY
942025	1	TAPER LOCK BUSHING
940034	1	ENGAGEMENT LINK
905012	1	GAS ENGAGEMENT ARM
910029	1	GAS ENGAGEMENT HANDLE
940021	1	TAPER LOCK BUSHING
942011	1	DRIVE SHEAVE
942012	2	SHEAVE
915089	1	BEARING
905011	1	REAR SHAFT GAURD
910031	1	BELT SHIELD
510195	4	WASHER, FLAT 5/16 STANDARD
110002	3	BOLT, 1/2-13 X 3.5
510066	5	BOLT, 5/16-18 X 1.25
510225	9	NUT, 1/2-13
510219	7	WASHER, 1/2 LOCK
710425	1	BOLT, 1/2-13 X 5.0
411120	1	KEY, 3/8 X 3/8 X 2.25
510228	1	KEY, 1/4 X 1/4 X 1
510208	7	NUT, 5/16-18
510425	4	NUT, 5/16-18 J-TYPE CAGE
110301	2	ROLL PIN 3/8 X 2.5
310030	4	BOLT, 1/2-13 X 2.0

CS1800 HITCH

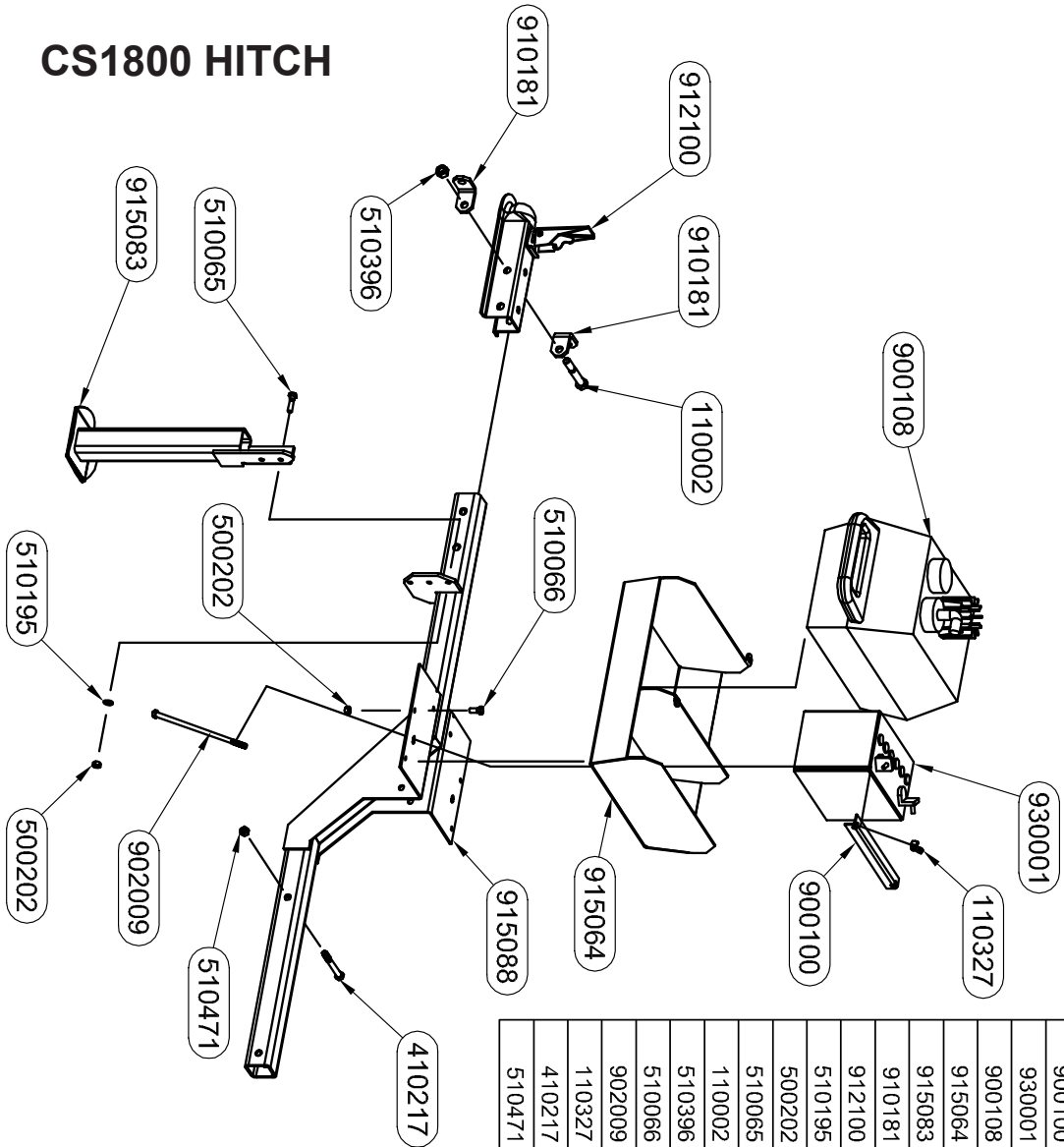

PART #	QTY	NAME
915088	1	TONGUE W/BRACKETS
900100	1	BATTERY HOLD DOWN
930001	1	BATTERY
900108	1	FUEL TANK
915064	1	TANK BOX WELDMENT
915083	1	JACK
910181	2	CHAIN MNT
912100	1	2" BALL COUPLER
510195	2	WASHER, FLAT 5/16 STANDARD
500202	6	NUT, 5/16-18 LOCK (NYLON)
510065	2	BOLT, 5/16-18 X 1.25
110002	3	BOLT, 1/2-13 X 3.5
510396	2	NUT, 1/2-13 LOCK UNL-TORQUE
510066	4	BOLT, 5/16-18 X 1.25
902009	2	BOLT, 5/16-18 X 8.0
110327	2	NUT, 5/16-18 WING
410217	2	BOLT, 3/8-16 X 3.5
510471	2	NUT, 3/8-16 LOCK

CS1800 HOPPER

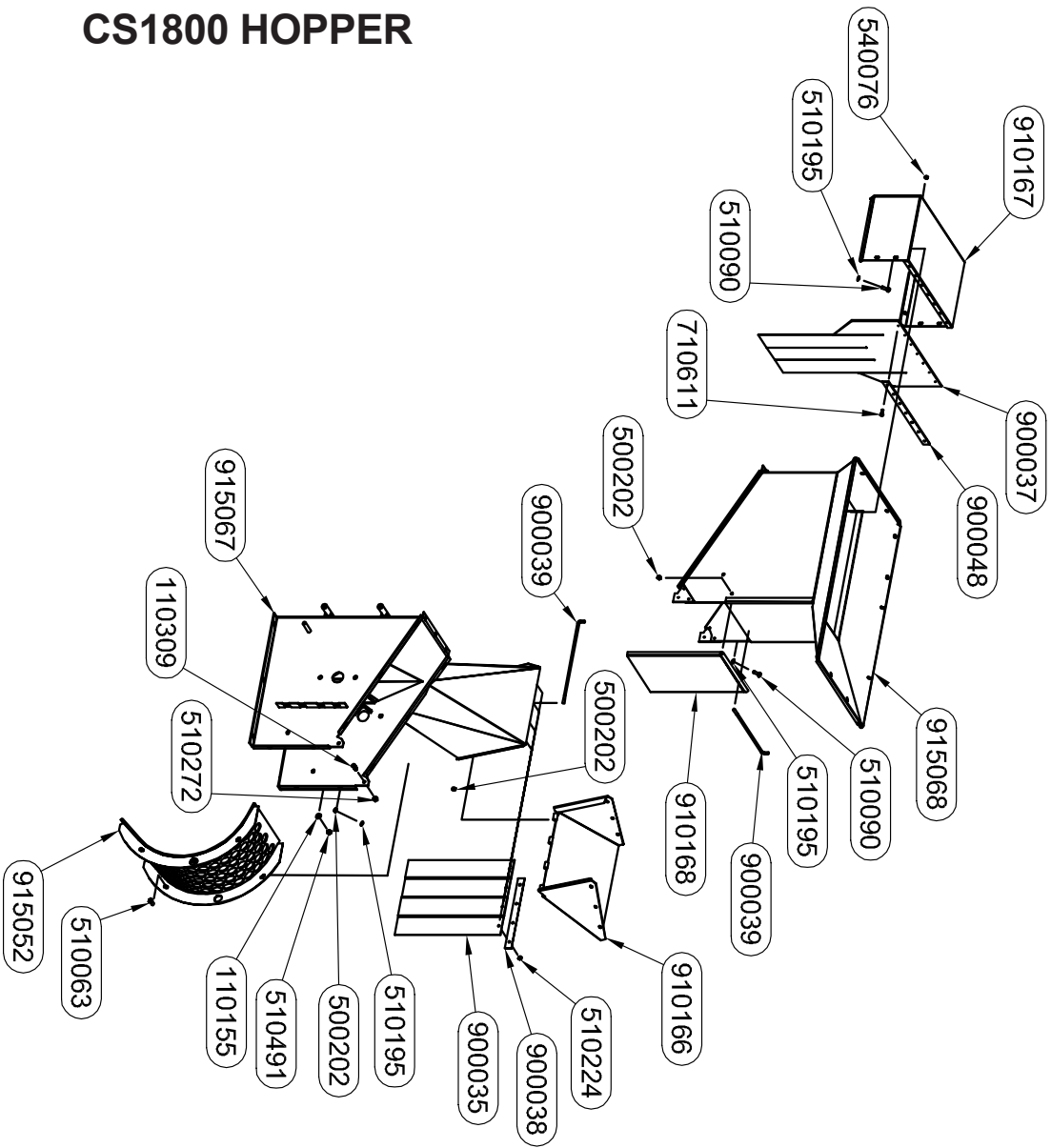

PART #	QTY	NAME
915067	1	LOWER HALF
900048	1	LONG FLAP MOUNT
900037	1	TUB SKIRT
900035	4	CHIPPER INTAKE SPOUT SKIRT
900038	1	SHORT FLAP MOUNT
910168	1	DISCHARGE DOOR
910167	1	TUB COVER
915052	1	1.5" GRATE
910166	1	SPOUT DOOR
915068	1	UPPER HALF
900039	2	REAR DOOR HINGE PIN
510195	4	WASHER, FLAT 5/16 STANDARD
500202	11	NUT, 5/16-18 LOCK (NYLON)
110155	4	WASHER, 3/8 FLAT, "SAE"
510272	2	NUT, 3/8-16
510063	6	BOLT, 3/8-16 X 1
540076	7	NUT, 1/4-20 LOCK(NYLOM)
710611	7	BOLT, 1/4-20 X .75
510090	17	BOLT, 5/16-18 X 1
510208	7	NUT, 5/16-18
510224	4	NUT, 1/4-20
110309	2	SCREW, 3/8-16 X 1 SLT
510491	4	NUT, 3/8-16 LOCK

CS-5400 ASSEMBLY

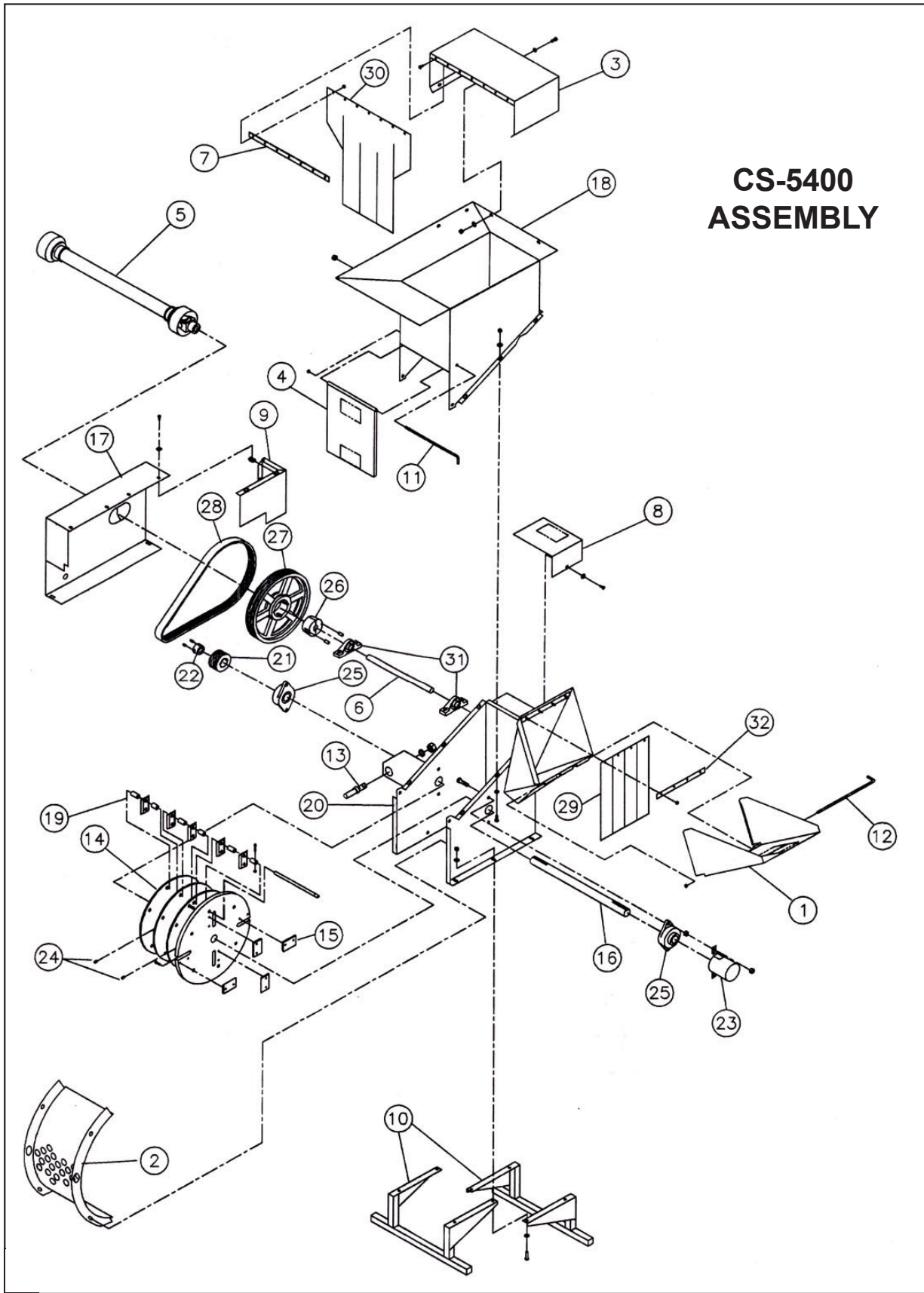

CS-5400 PART NO.S

ITEM NO.	PART NO.	QTY.	DESCRIPTION
1	910166	1	SPOUT DOOR
2	915052	1	1.5" GRATE WELDMENT
3	910167	1	TUB COVER
4	910168	1	DISCHARGE DOOR
5	940015	1	PTO SHAFT (SIZE 2)
6	940031	1	JACK SHAFT
7	900048	1	LONG FLAP MOUNT
8	910169	1	PTO JACK SHAFT GUARD
9	910170	1	BELT SHIELD BACK
10	915086	2	LEG STAND
11	900039	1	DOOR HINGE PIN
12	900039	1	DOOR HINGE PIN
13	910002	2	3-POINT PIN w/HARDWARE
14	915084	1	ROTOR ASSEMBLY, COMPLETE
15	905007	1	CHIPPER KNIFE KIT
16	940030	1	ROTOR SHAFT
17	915050	1	PTO FRONT BELT SHIELD
18	915048	1	PTO UPPER HALF MAINFRAME
19	905008	1	SHREDDER KNIFE KIT
20	915049	1	PTO LOWER HALF
21	942009	1	TAPER LOCK SHEAVE (4/3V3/65-1610)
22	940112	1	TAPER LOCK BUSHING (1610 x 1.5" IK)
23	905011	1	REAR SHAFT GUARD
24	110301	2	ROTOR SHAFT ROLL PIN
25	942012	2	FLANGE BEARING (2-BOLT ECC LOCK 1.5")
26	940013	1	TAPER LOCK BUSHING (2517 x 1")
27	940014	1	DRIVE SHEAVE (4/3V14.0-2517)
28	942001	1	DRIVE BELT (4/3VX600)
29	900035	1	CHIPPER INTAKE SPOUT SKIRT
30	900037	1	TUB SKIRT
31	940009	2	PILLOW BLOCK BEARING (1")
32	900038	1	SHORT FLAP MOUNT (PAINTED)

OPTION - CHIPPER/SHREDDER BLOWER ATTACHMENT

Part No. 900036

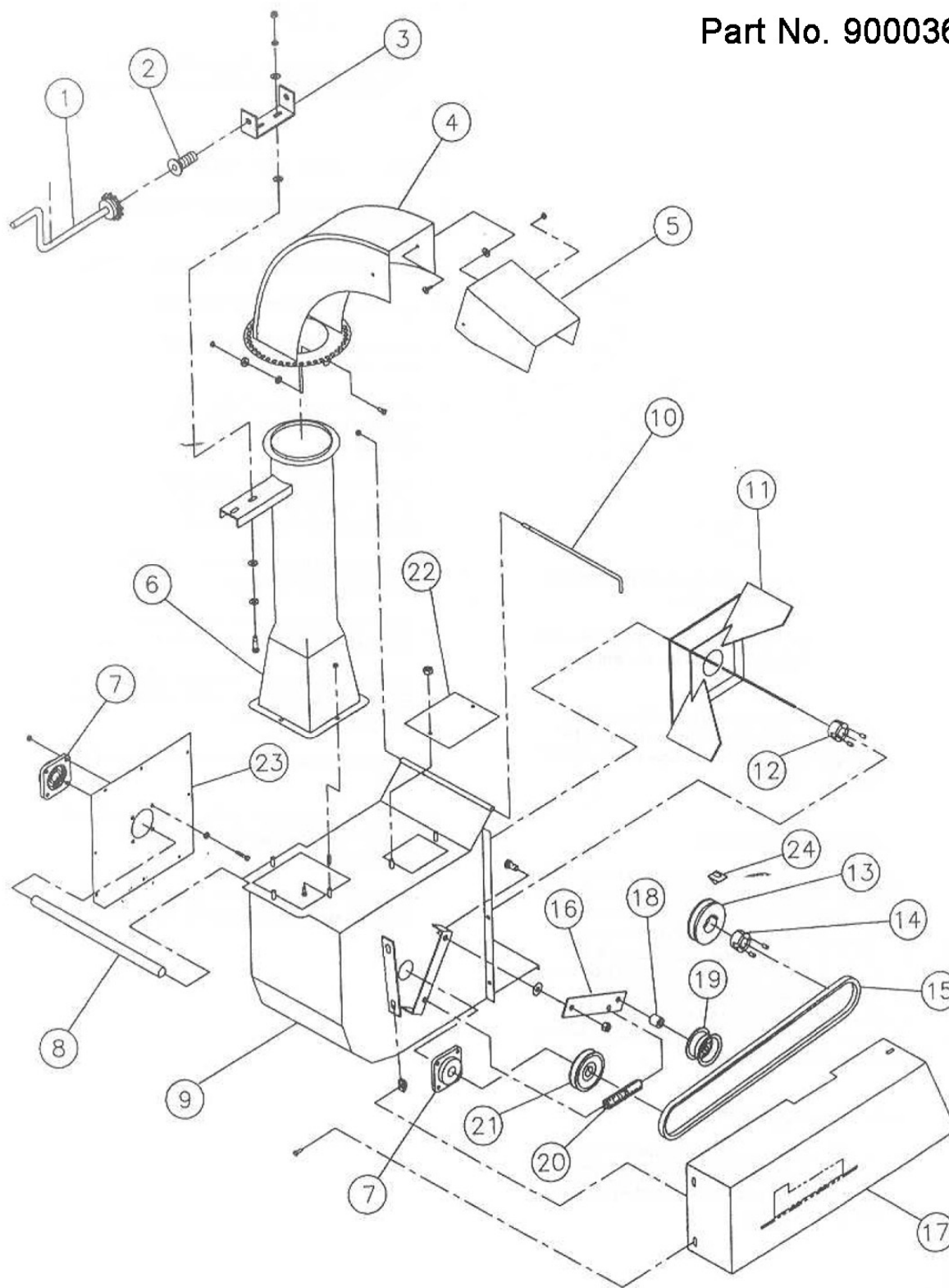

Harper/Goossen Chipper/Shredder Blower Attachment Package - 900036

Item	Part No.	Description	
1-2-3	915057	CRANK ASSEMBLY, SHORT HANDLE	*
4	915062	UPPER SPOUT ASSEMBLY	*
5	910400	DIRECTIONAL SPOUT DEFLECTOR	*
6	915060	LOWER DIRECTIONAL SPOUT	*
7	942036	1" FLANGE BEARING	
8	900050	BLOWER IMPELLER SHAFT, 1" KEYED	
9	915058	BLOWER ASSEMBLY	
10	900039	REAR DOOR HINGE PIN	
11	915059	VAC IMPELLER ASSEMBLY	
12	942028	VAC IMPELLER TAPER LOCK	
13	942027	BLOWER DRIVE SHEAVE	
14	940112	TAPER LOCK BUSHING (1610 x 1.5" IK)	
15	942026	BLOWER DRIVE BELT	
16	940033	TENSION ARM	
17	915061	BLOWER BELT SHIELD ASSEMBLY	
18	910171	SPACER, 1"OD X .56"ID X 1"	
19	940001	NARROW IDLER	
20	910018	SPRING, FINGER ADJUSTER	
21	942024	BLOWER IMPELLER SHAFT SHEAVE	
22	910402	CLEANOUT COVER	
23	910401	IMPELLER DOOR	
24	910030	MOUNT TAB	

* Refer to Directional Blower Spout diagram

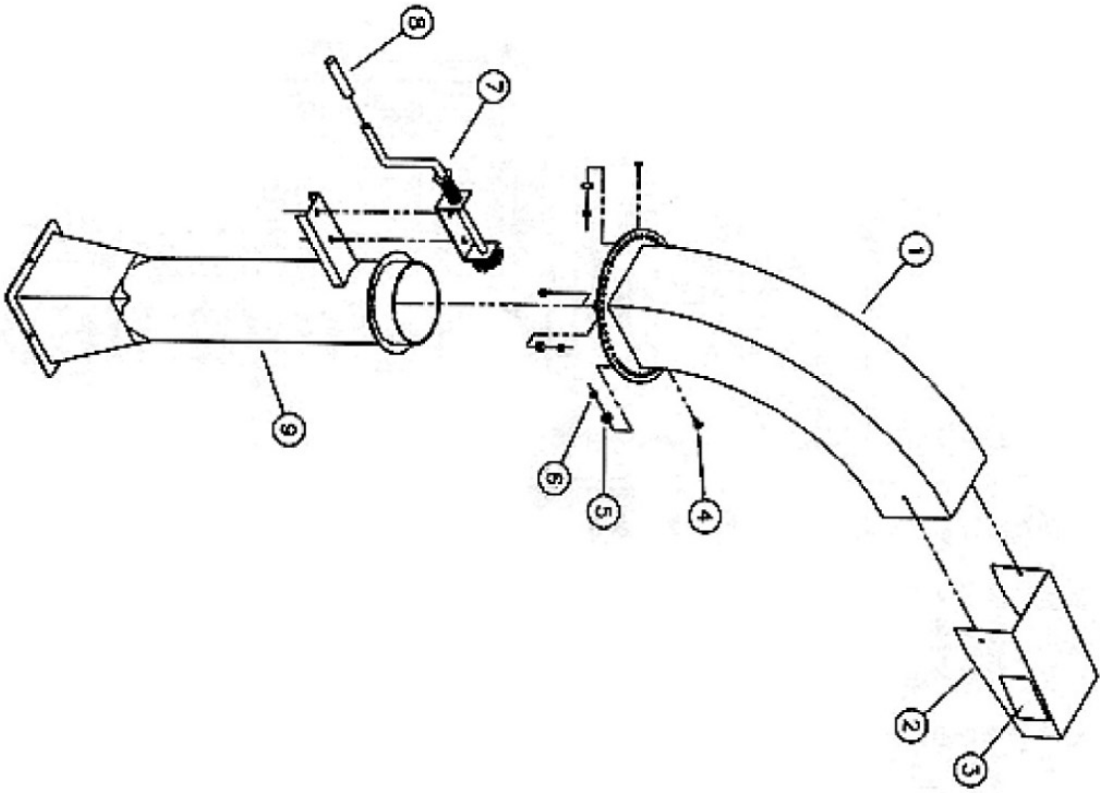

OPTION
DIRECTIONAL BLOWER SPOUT - 905005

#	PART #	QTY	NAME
1	915062	1	UPPER DIRECTIONAL SPOUT ASSY
2	910400	1	DIRECTIONAL SPOUT DEFLECTOR
3	902036	2	DECAL, STAY CLEAR OF CHUTE
4	110422	3	BOLT, 5/16-18 X .75
5	540079	3	BEARING, BALL, 608 2RS, .315"
	110298	3	* WASHER, 1/4 FLAT SAE
6	110600	3	NUT, 5/16-18, HEX LOCK 2 WAY
7	915119	1	CRANK ASSY, LONG HANDLE
8	902012	1	COVER, CRANK HANDLE
9	915060	1	LOWER DIRECTIONAL SPOUT ASSY

* Place washer between bearing and flange so that bearing turns freely.
Grease area where lower spout contacts upper spout.

HARDWARE FOR ATTACHING DEFLECTOR TO UPPER SPOUT

111005	2	SCREW, 5/16-18X.75,SLOT MACH RH
110603	2	NUT, 5/16-18, LOCK (NYLON)

HARDWARE FOR ATTACHING CRANK TO LOWER SPOUT

110556	2	BOLT, 3/8-16 X 1, CARRIAGE
110676	8	* WASHER, 3/8 FLAT STANDARD
110618	2	NUT, 3/8-16, LOCK NYLON INSERT

* Use washers to bush up crank so that teeth fully mesh into holes in upper spout. Crank and spout should turn freely.

HARDWARE FOR ATTACHING LOWER SPOUT TO BASE UNIT

110423	4	BOLT, 5/16-18 X 1
110674	4	WASHER, 5/16 LOCK
110608	4	NUT, 5/16-18

ROTOR

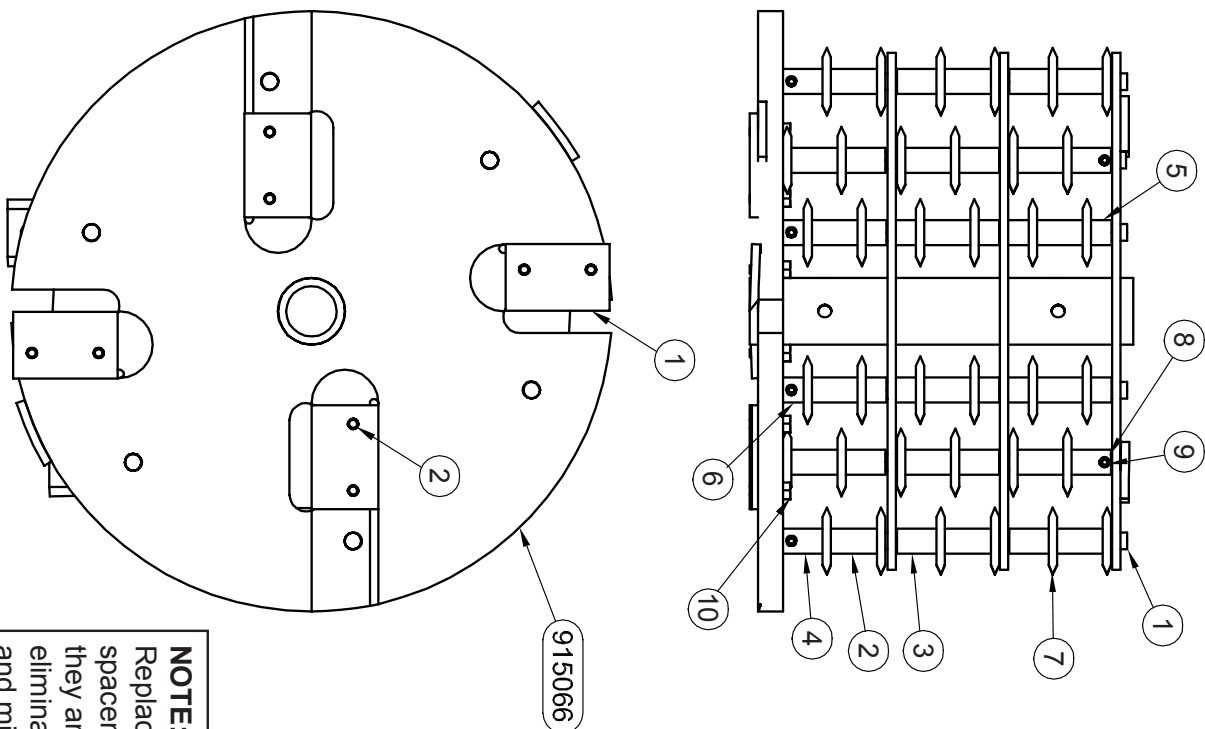

NOTE:
 Replace shredder knives and spacers in the same manner they are removed. This will eliminate improper balance and misalignment of knives.

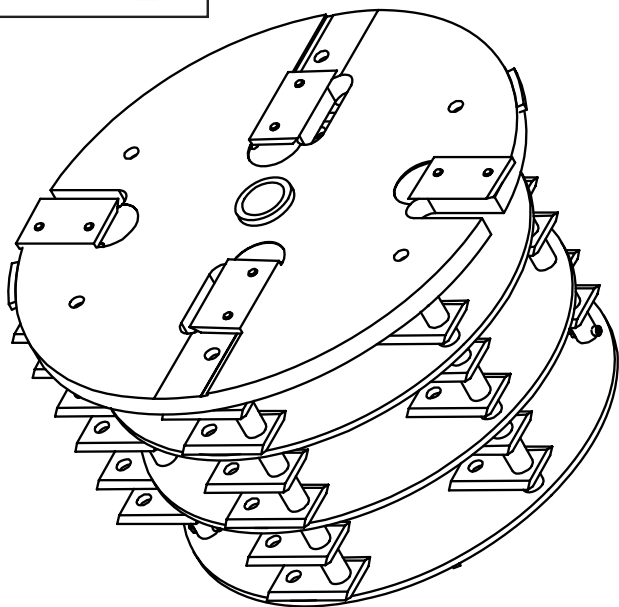

PART #	QTY	NAME
915066	1	DRUM
905008	1	SHREDDER KNIFE KIT
ITEM # 1	6	KNIFE ROD
2	18	1.375 SPACER
3	8	1.188 SPACER
4	4	1.188 SPACER W/HOLE
5	10	.615 SPACER
6	2	.615 SPACER W/HOLE
7	36	SHREDDER KNIFE
8	6	NUT, 10-24 NYLON
9	6	BOLT, 10-24 x 1.25 SHCS
10	8	BOLT, 5/16-18 x 1
905007	1	CHIPPER KNIFE KIT
ITEM # 1	4	CHIPPER KNIFE
2	8	BOLT, 5/16-18 X 1.0, HHCS

CS-1800

HARPER
Goodwin
Chipper/Shredder

902062

⚠ DANGER

Do not place branches larger than 1 1/4 inches diameter in shredder hopper.



Do not place branches larger than 1 1/4 inches diameter in shredder hopper.

Failure to comply can result in possible injury or death!

902040

⚠ DANGER

ROTATING CHOPPER CONTACT CAN CAUSE INJURY

TO PREVENT INJURY FROM CHOPPERS:

- STAY AWAY FROM ALL RUNNING OPERATION.
- KEEP OTHERS AWAY

900009

HARPER
Goodwin

900017

⚠ WARNING

- BEFORE OPERATING:**
1. Read and understand all instructions and warnings before operating this equipment.
 2. Do not wear alcohol to operate this machine.
 3. Do not operate the machine in the vicinity of open flames.
4. Do not operate the machine in the vicinity of overhead power lines.
 5. Do not operate the machine in the vicinity of overhead power lines.
 6. Do not operate the machine in the vicinity of overhead power lines.
 7. Do not operate the machine in the vicinity of overhead power lines.
 8. Do not operate the machine in the vicinity of overhead power lines.
 9. Do not operate the machine in the vicinity of overhead power lines.
 10. Do not operate the machine in the vicinity of overhead power lines.
 11. Do not operate the machine in the vicinity of overhead power lines.
 12. Do not operate the machine in the vicinity of overhead power lines.
 13. Do not operate the machine in the vicinity of overhead power lines.
 14. Do not operate the machine in the vicinity of overhead power lines.

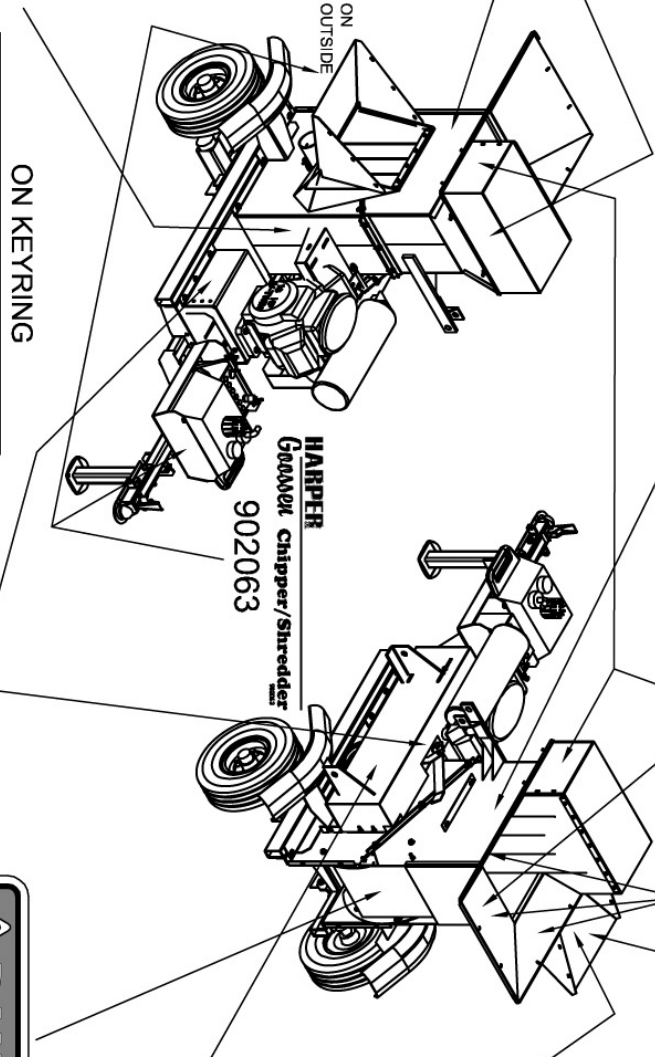

⚠ CAUTION

1. KEEP ALL GUARDS IN PLACE.
2. STOP MACHINE TO ADJUST & LUBRICATE.
3. IF MECHANISM BECOMES CLOGGED DISCONNECT POWER BEFORE CLEANING.
4. KEEP HANDS, FEET AND CLOTHING AWAY FROM POWER-DRIVEN PARTS.

900008

900008

⚠ CAUTION

DO NOT START THIS ENGINE UNTIL BATTERY HAS BEEN SERVICED OR WARRANTY WILL NOT BE VALID

902041

902039

⚠ CAUTION

AREA AROUND ENGINE MUST BE KEPT CLEAR OF FLAMMABLE MATERIAL

900007

⚠ DANGER

STAY CLEAR OF CHUTE WHILE IN OPERATION.

DISCHARGED MATERIAL CAN CAUSE DEATH OR SERIOUS INJURY.



902036

HARPER

Goosnell Chipper/Shredder

902062

THIS EQUIPMENT DESIGNED FOR NORMAL OPERATING SPEED
540 RPM
KEEP U-JOINT ANGLE SMALL AND EQUAL. DO NOT EXCEED 15° ANGLE ON EACH U-JOINT.

902001

BEFORE OPERATING!

1. Before starting, always use proper operation, read and operate the machine.
2. Do not operate the machine in the vicinity of spectators.
3. Always wear safety glasses, eye protection, and ear protection.
4. Never operate the machine in the vicinity of spectators.
5. Never operate the machine in the vicinity of spectators.
6. Always use proper operation, read and operate the machine.
7. Always use proper operation, read and operate the machine.
8. Always use proper operation, read and operate the machine.
9. Always use proper operation, read and operate the machine.
10. Always use proper operation, read and operate the machine.
11. Always use proper operation, read and operate the machine.
12. Always use proper operation, read and operate the machine.
13. Always use proper operation, read and operate the machine.
14. Always use proper operation, read and operate the machine.

902041

ROTATING CHIPPER CONTACT CAN CAUSE INJURY

TO PREVENT INJURY FROM ROTATING CHIPPER, STAY AWAY FROM INLET DURING OPERATION. KEEP OTHERS AWAY.

900009

900008

1. KEEP ALL GUARDS IN PLACE.
 2. STOP MACHINE TO ADJUST & LUBRICATE.
 3. IF MECHANISM BECOMES CLOGGED, DISCONNECT POWER BEFORE CLEANING.
 4. KEEP HANDS, FEET AND CLOTHING AWAY FROM POWER-SHAFT PARTS.

900008

900008

! DANGER

Do not place branches larger than 1 1/4 inches diameter in shredder hopper.

Do not place branches larger than 1 1/4 inches diameter in shredder hopper.

Failure to comply can result in possible injury or death!

902040

902040

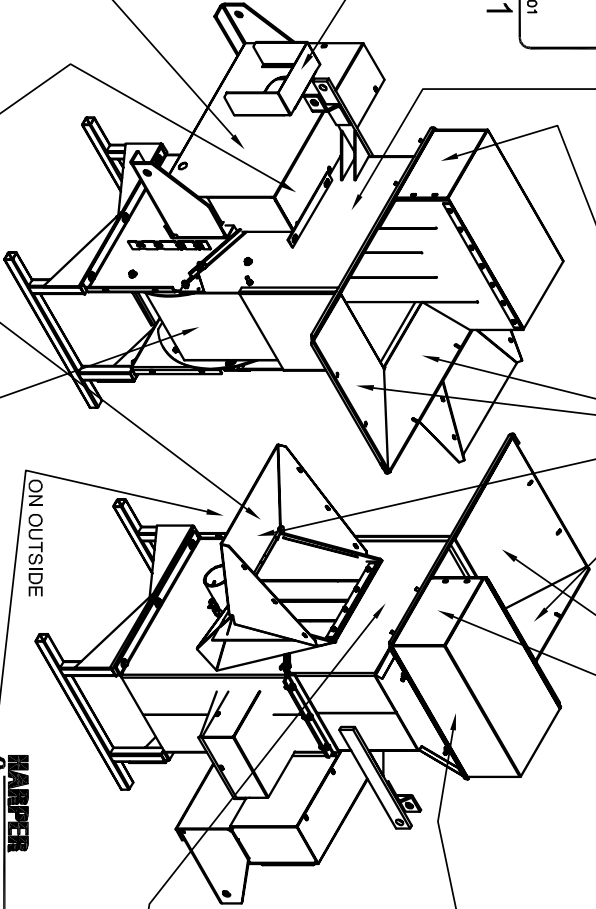

HARPER
 Goosnell
 Chipper/Shredder

902063

HARPER
 Goosnell

900012

! DANGER

STAY CLEAR OF CHUTE WHILE IN OPERATION. DISCHARGED MATERIAL CAN CAUSE DEATH OR SERIOUS INJURY.

902036

902036

CS-5400

